



## Vertical and horizontal freezers WHALE 2000G



### Product categories



### Technical features





WHALE 2000G						
Length mm		1880	2500	3750	MT2020	MT2230
WHALE 2000G	LG300	•	•	•	•	•
	HG400	•	•	•	•	•
Display area m2	LG300	3.72	4.95	7.42	2.30	2.30
	HG400	4.13	5.50	8.23		
Loading area m2	LG300	3.79	5.04	7.56	2.16	2.16
	HG400					
Net storage capacity dm3	LG300	1278.00	1700.00	2550.00	682.00	682.00
	HG400					
End thickness mm	Panoramic	70 (+ 104 )				
	Blind	51 (+ 104 )				



WHALE 2000G MT - LG300

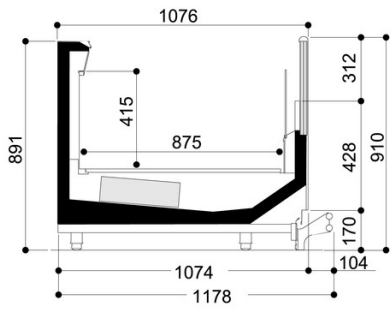

WHALE 2000G MT - HG400

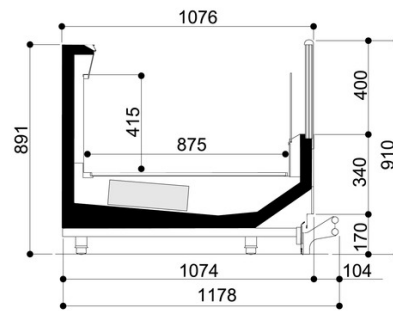

WHALE 2000G 1EV - LG300

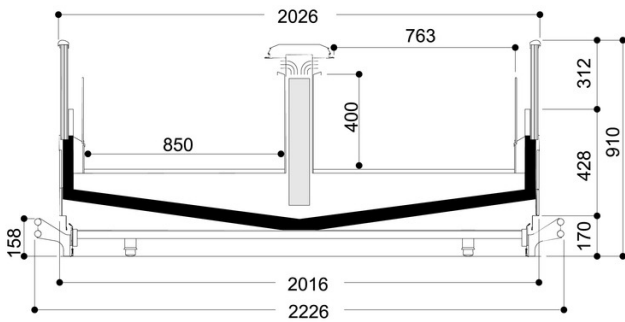

WHALE 2000G 1EV - HG400

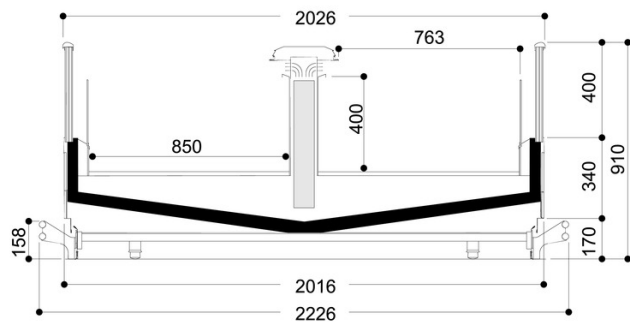



WHALE 2000G 2EV - LG300

WHALE 2000G 2EV - HG400

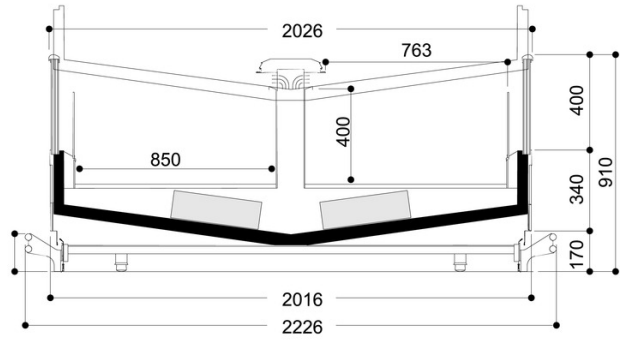
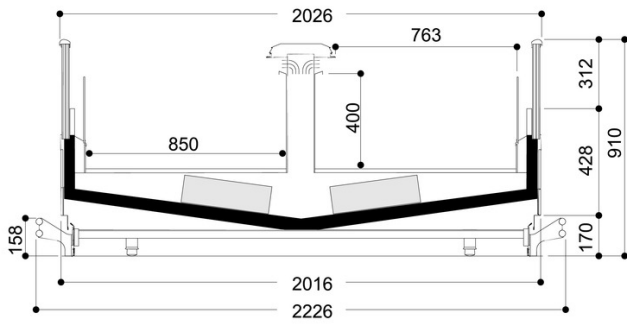



## Legend

 Meat	 Chicken	 Fish	 Pre-packed fish
 Delicatessen	 Cheese	 Dairy products	 Gastronomy
 Pastries	 Pre-packed fruit and vegetables	 Fruits and Vegetables	 Sandwiches
 Drinks	 Pizza	 Bread	 Frozen food and ice cream
 Off-cycle defrost	 Electric defrost	 Hot-gas defrosting system	 Manual defrost
 Ventilated	 Static	 Incorporated condensing unit	 Remote condensing unit
 Bagnomaria	 Ceramic glass	 Ice	 VSD Inverter technology
 LED lighting	 Zero C doors	 High efficiency fans	 R290 Propane refrigerant gas (R290)
 R134a R-134a - 400V/3PH/50Hz	 R404A R404A - 400V/3PH/50Hz	 R744 R744 - 400V/PH/50Hz	 Compressor hermetic reciprocating
 Hermetic scroll compressor	 Semi-hermetic reciprocating compressor	 VSD Inverter technology	 External installation
 Machinery room	 Soundproof housing	 On board condenser	 Remote condenser
 DUAL Medium & Low temperature			